

OPTIONAL PLAQUE	
SYMBOL	WHITE REFLECTIVE
BORDER	WHITE REFLECTIVE
BACKGROUND	GREEN REFLECTIVE

SPECIFICATION REFERENCE TABLE  
 MATERIALS AND TESTS DIVISION SPECIFICATIONS  
 ALUMINUM SIGN BLANKS D-9-7110  
 REFLECTIVE SHEETING, TYPE C  
 (HIGH SPECIFIC INTENSITY) D-9-8300

NOTES:

1. THE ALPHABETS AND LATERAL SPACING BETWEEN LETTERS AND NUMERALS SHALL CONFORM WITH THE TEXAS "MANUAL ON UNIFORM TRAFFIC CONTROL DEVICES FOR STREETS AND HIGHWAYS", LATEST EDITION, AND ANY APPROVED CHANGES THERETO. LATERAL SPACING OF TEXT SHALL PROVIDE A BALANCED APPEARANCE. ALL MATERIALS SHALL CONFORM TO TXDOT DEPARTMENT SPECIFICATIONS
2. LEGEND SHALL BE APPLIED BY REVERSE SCREENING PROCESS WITH TRANSPARENT COLORED INK. CUT-OUT WHITE REFLECTIVE SHEETING APPLIED TO COLORED BACKGROUND OR COMBINATION THEREOF. BACKGROUND SHALL BE REFLECTIVE SHEETING (TYPE C).
3. SIGN BLANKS SHALL BE 0.080" THICK AND ONE PIECE SHEET ALUMINUM ALLOY CONFORMING WITH TXDOT DEPARTMENT SPECIFICATION "ALUMINUM SIGNS (TYPE A)."

The City of San Marcos  
 Engineering and Capital Improvements

CURRENT AS OF  
 1/1/2021

GROUND MOUNTED TRAFFIC AND  
 STREET NAME SIGNS

RECORDED COPY SIGNED BY  
 LAURIE MOYER, P.E.

3-16-2015  
 ADOPTED

THE ARCHITECT/ENGINEER ASSUMES  
 RESPONSIBILITY FOR APPROPRIATE  
 USE OF THIS STANDARD

824-2-SM

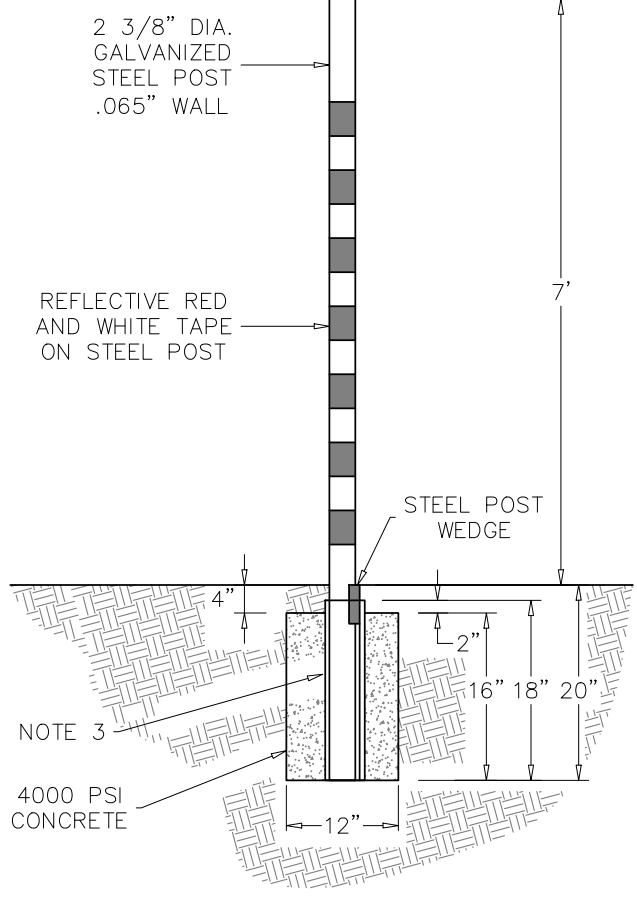
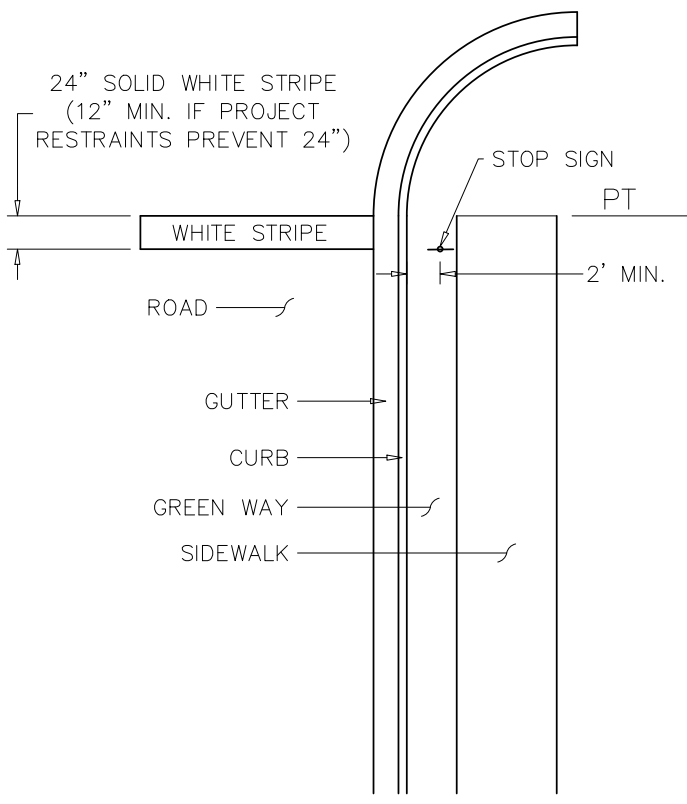
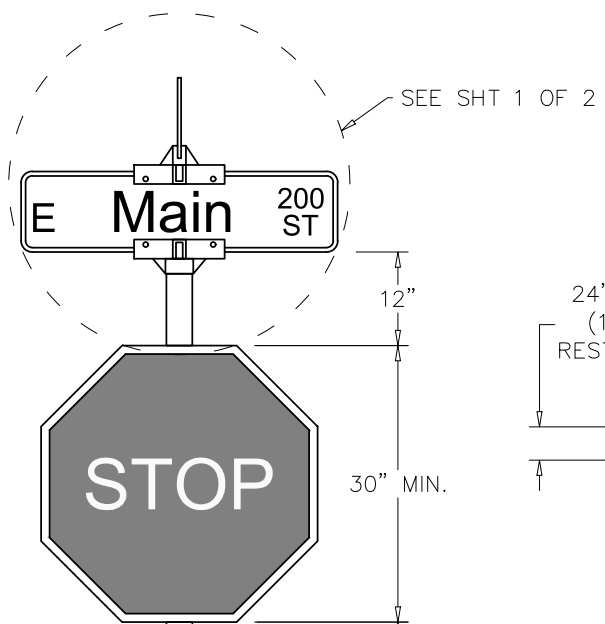

NOTES:

1. SIGNS ON STATE FACILITIES SHALL CONFORM TO TXDOT STANDARDS.
2. DISTANCE FROM THE EDGE OF THE STREET POST TO THE FACE OF THE CURB SHALL BE A MINIMUM OF 2'.
3. SLEEVE WILL BE 18" GALVANIZED STEEL PIPE WITH O.D. 2 7/8" AND I.D. 2 5/8"

<p>The City of San Marcos Engineering and Capital Improvements</p>	<p>CURRENT AS OF 1/1/2021</p>	<p><b>GROUND MOUNTED TRAFFIC AND STREET NAME SIGNS</b></p>	
<p>RECORDED COPY SIGNED BY  LAURIE MOYER, P.E.</p>	<p>3-16-2015 <u>ADOPTED</u></p>	<p>THE ARCHITECT/ENGINEER ASSUMES RESPONSIBILITY FOR APPROPRIATE USE OF THIS STANDARD</p>	<p style="text-align: center;"><b>824-2-SM</b> N.T.S. STANDARD DETAIL</p>